

HOCHIKI CONVENTIONAL DETECTOR RANGE INSTALLATION INSTRUCTIONS

Products Covered: Detectors – SOC-E3N, SOC-E3N(WHT), SOC-E3(WHT), SOC-E3(HFP), SLR-E3/SLR-E3N, DCD-AE3, DCD-CE3, DFJ-AE3, DFJ-CE3
Bases - YBN-R/6, YBN-R/6SK, YBO-R/6PA, YBO-R/6R, YBO-R/6RN, YBO-R/6RS

Introduction

The Conventional Detectors listed above all utilise three terminals, which means they can drive a remote indicator. They also operate within a wide voltage range (9.5 - 30V) allowing installation within both fire AND security systems. Each detector can use a common mounting base (YBN-R/6) which is electronics free, or any other base from the range of special bases as shown below:

Detector	Base	Description
SOC Range SLR Range DCD Ranges DFJ Range	YBN-R/6	Standard Base
	YBN-R/6SK	Base with in-line Schottky Diode
	YBO-R/6PA	Base compatible with Protector Alarms Systems
	YBO-R/6R	Relay Base (Latching)
	YBO-R/6RN	Relay Base (Non-latching)
	YBO-R/6RS	Relay Base (Latching with Schottky Diode)

** When using older variants of those mounting bases listed above, the three locating tabs on the bottom edge of the SLR-E3N will need to be carefully removed with pliers (see drawing on page 2).*

Please observe the guidelines below before installation and maintenance. Hochiki cannot guarantee a detector's performance if these guidelines are not followed.

Caution

Hochiki detectors cannot be used to prevent fire itself, they are only intended to detect a certain characteristic of fire. The detector DFJ(Range) and DCD(Range) are used to detect conditions and changes in temperature and cannot detect smoke and other phenomena. When installing the detector, check that the location of each one has been planned according to appropriate fire regulations or recommendations.

Please note:- These Detectors are designed for indoor use only.

Certain actions can cause permanent damage to the detector. If the detector is subjected to any of the following it should not be used (or it should be located where the phenomenon does not exist):

- Situations in which condensation exists.
- Situations in which corrosive gases exists.
- Situations in which obstacles exist, which could impede airflow to the detector.
- Situations in which dust or steam exists
- Disassembly and re-assembly (except SLR-E3/SLR-E3N maintenance).
- Impact or shock.
- Touching the thermistor located in the centre of the detector (DFJ Range and DCD Range Heat detectors only).

If damage is suspected after a fire has occurred, the detector should be replaced. After installation, all detectors on the fire alarm system should be tested to confirm correct operation. Only suitably trained engineers should carry out installations and maintenance. The detector must be subject to periodic maintenance during regular service visits. This period should be outlined in the appropriate standards or recommendations. If there are no such standards existing, Hochiki recommend that the minimum period of maintenance should be 1 year and that the following should be taken into account:

- A regular operation test should be performed.
- A visual check for staining and mechanical damage should be made.
- Operation should only be checked by equipment that is capable of exceeding the required detection threshold. Detector operation should not be tested with a naked flame or open fire.

A dust cover is included with the detector to prevent contamination during installation. **The dust cover must be removed for the detector to operate.**

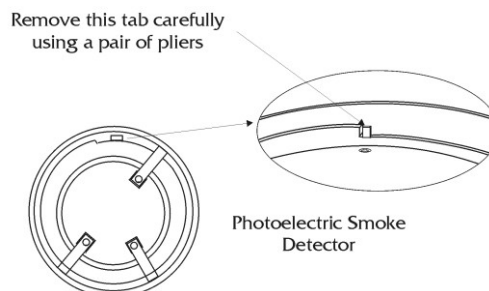

Head Locking Mechanism

The detectors can be locked onto their relevant bases by removing a plastic lug on the underside of the Detector. The Detector can then be removed by using a removal tool which is available from Hochiki Europe (UK) Ltd.

Wiring

The wiring diagram for the conventional detector base should be made as shown.

A: Zone (+) **B:** Zone (-) **C:** Cable Screen

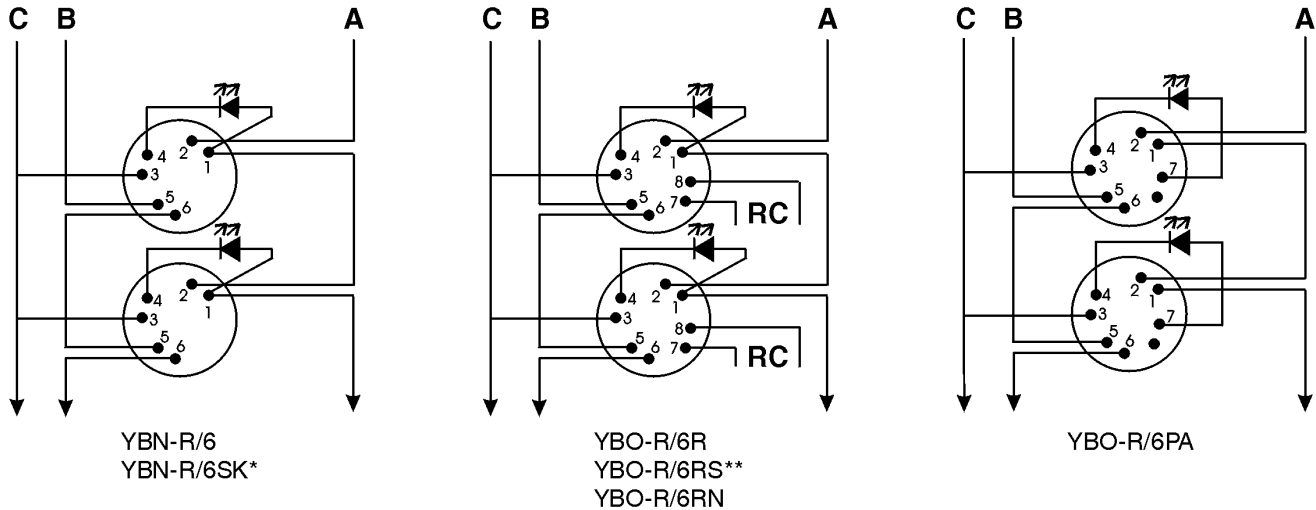

RC Relay Contacts - a flying lead on either terminal 7 or 8 selects either N/C or N/O (supplied as N/C)

Remote Indicator

*The Schottky Diode Bases can easily be converted into non-Schottky versions by removing the Schottky diode, which is fitted between terminals 1 and 2.

**The Schottky Diode Bases can easily be converted into non-Schottky versions by cutting out and removing the Schottky diode, which is soldered on the underside between terminals 1 and 2.

Note

The YBO-R/6RN base will automatically reset the detector every 8 - 15 seconds after it has entered an alarm state. If the detector remains above its alarm threshold after a reset the LEDs will illuminate again. This will continue until a reset is achieved. The relay contacts (and Remote Indicator) will not change state until the reset is successful.

 Protocol specified in TI/006	DCD-AE3	0832-CPD-0116	05	EN54-5 Point type heat detectors
	DCD-CE3	0832-CPD-0117	05	EN54-5 Point type heat detectors
	DFJ-AE3	0832-CPD-0118	05	EN54-5 Point type heat detectors
	DFJ-CE3	0832-CPD-0119	05	EN54-5 Point type heat detectors
	SLR-E3	0832-CPD-0111	05	EN54-7 Point type smoke detectors
	SLR-E3N	0832-CPD-0614	08	EN54-7 Point type smoke detectors
	SOC-E3N	0832-CPR-F1518/16		EN54-7 Point type smoke detectors
	SOC-E3N(WHT)			
	SOC-E3(WHT)			
	SOC-E3(HFP)	0832-CPR-F1519/16		EN54-7 Point type smoke detectors
	YBO-R/6R	0832-CPD-1112	09	EN54-18 Input/Output modules
YBO-R/6RS	0832-CPD-1113	09	EN54-18 Input/Output modules	
YBO-R/6RN	0832-CPD-1114	09	EN54-18 Input/Output modules	



Hochiki Europe (UK) Ltd
 Grosvenor Road, Gillingham Business Park,
 Gillingham, Kent, ME8 0SA, England Telephone:
 +44(0)1634 260133 Facsimile: +44(0)1634 260132
 Email: sales@hochikieurope.com
 Web: www.hochikieurope.com

Hochiki Europe (UK) Ltd. reserves the right to alter the specification of its products from time to time without notice. Although every effort has been made to ensure the accuracy of the information contained within this document it is not warranted or represented by Hochiki Europe (UK) Ltd. to be a complete and up-to-date description. Please check our web site for the latest version of this document.